

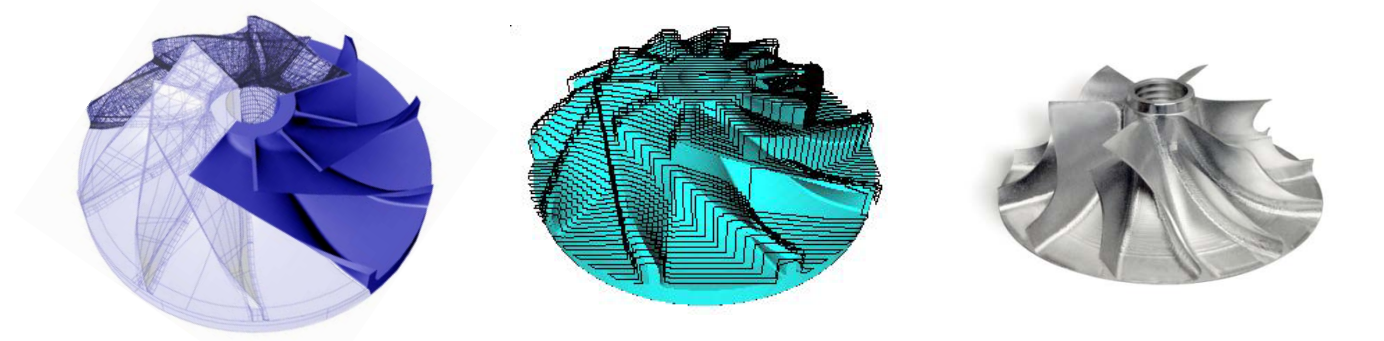

# GPU Accelerated Path Planning for Multi-Axis Machine Tool Enhancement

Joshua Tarbuton, Thomas Kurfess – Clemson University | Thomas Tucker – Tucker Innovations



## ABSTRACT

In this research, a graphics-based approach is applied to the tool path and trajectory planning problem found in machining and robotics applications. Graphics concepts are used to re-cast the tool path planning problem into one that is parallel and best solved by exploiting the parallel processing power of graphics processing units or GPU's. This entirely new framework for tool path planning is to use a ray casting approach on a voxelized model of the part to be manufactured by a machine tool such as a mill or lathe. In this approach, rays are cast from a virtual tool cutter in space at a part model represented by voxels for the twofold purpose of: fast intersection detection with the rays and fast computations on the voxel volume. Once the part has been voxelized, a parameterized plane is created in space that represents the tools cutting plane. Rays are cast from this plane and their intersection with the voxelized part is stored. The location of the intersection of the ray with the part is used to create a raster path. The cutting path is created for all types of surfaces including those that are freeform. The algorithm has successfully been used to create 2.5-, 3-, and 4-axis tool paths.

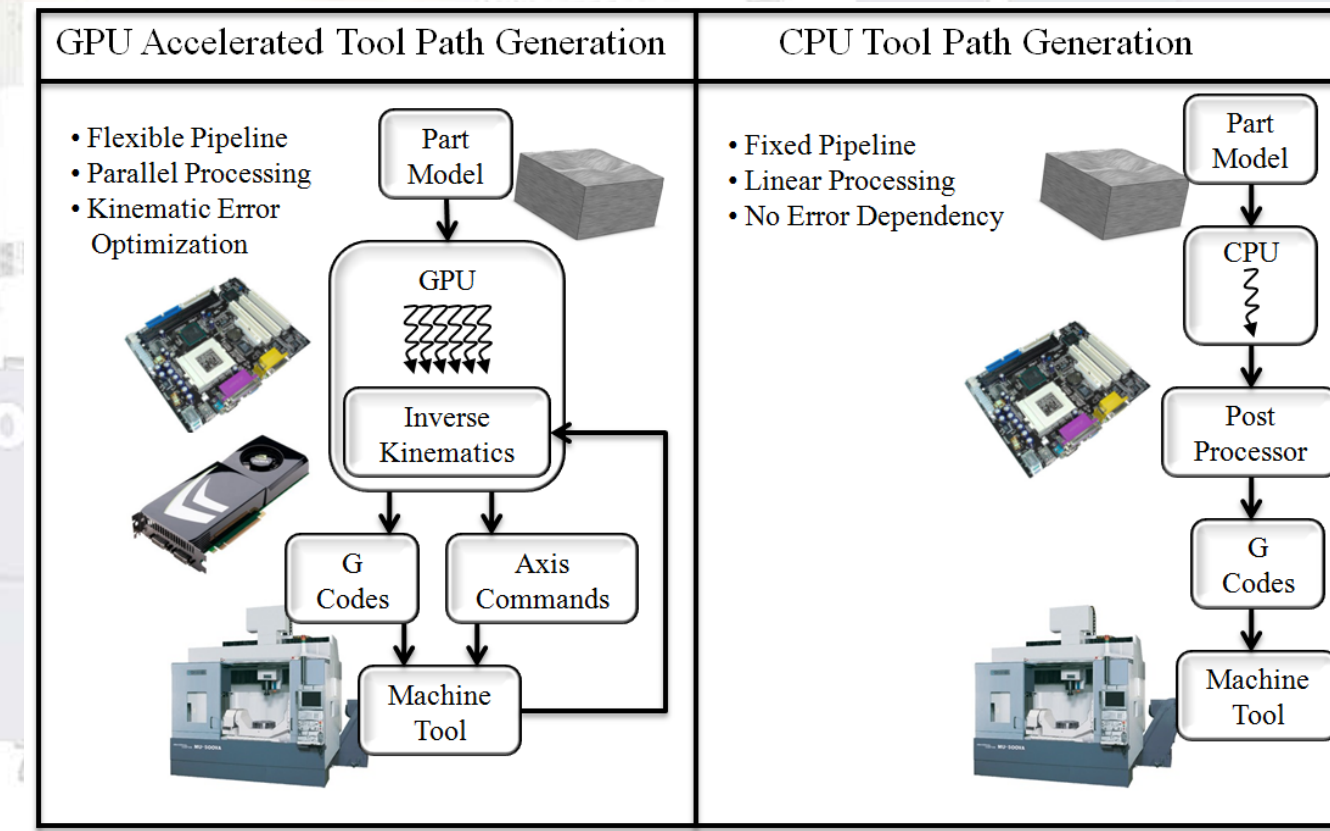

## UNCUT MATERIAL DETECTION AND REMOVAL

### Cast Rays at Part

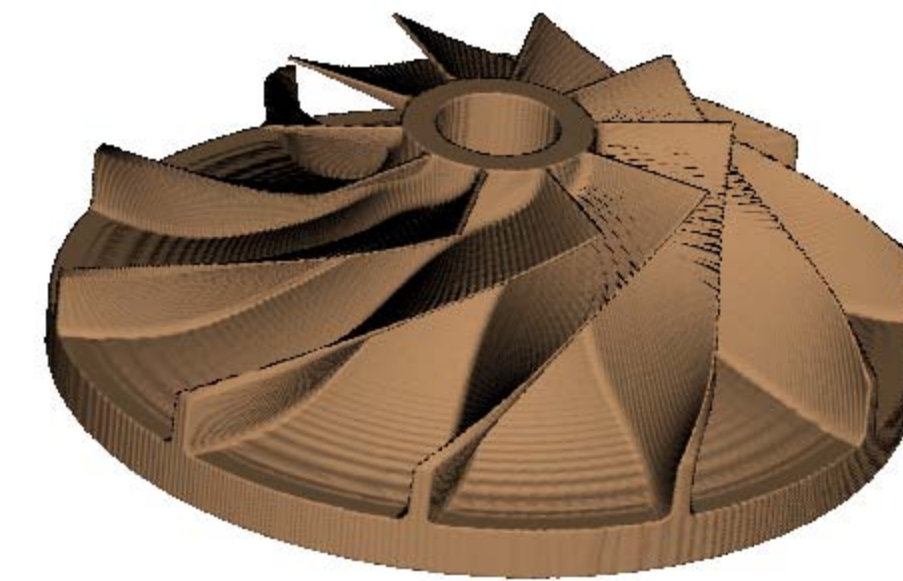

### Re-Orient Cutting Plane

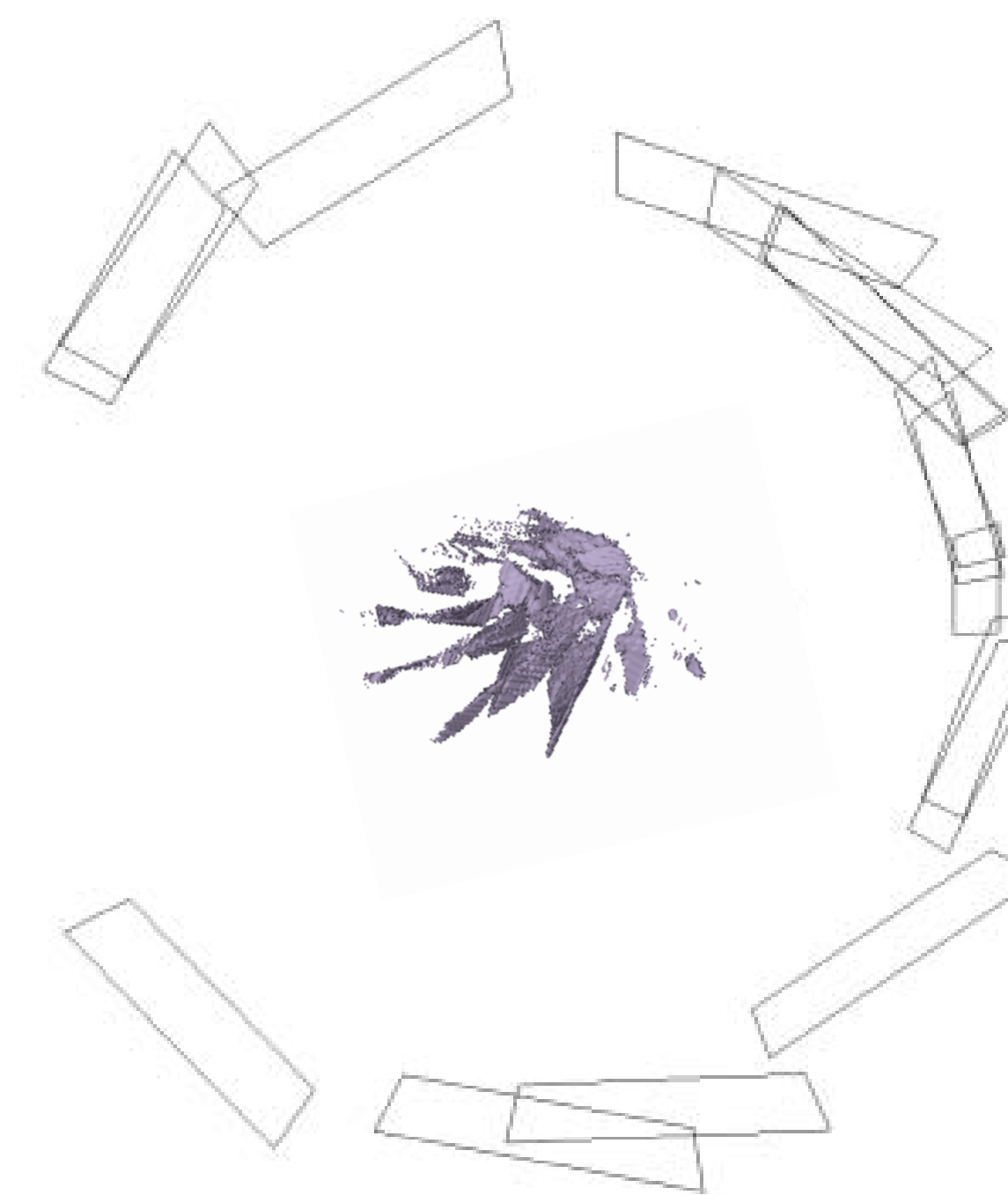

### Detect Uncut Material

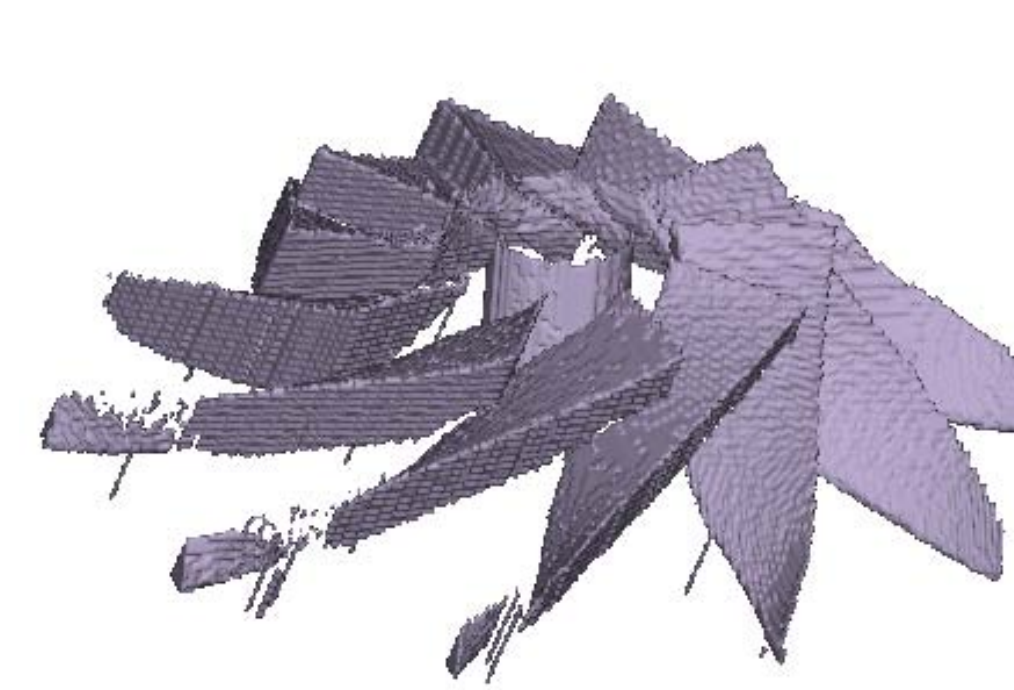

## WORK IN PROGRESS – IMAGE PROCESSING POSITION CONTROL

### Traditional CNC machine:

Feed Forward Error Compensation

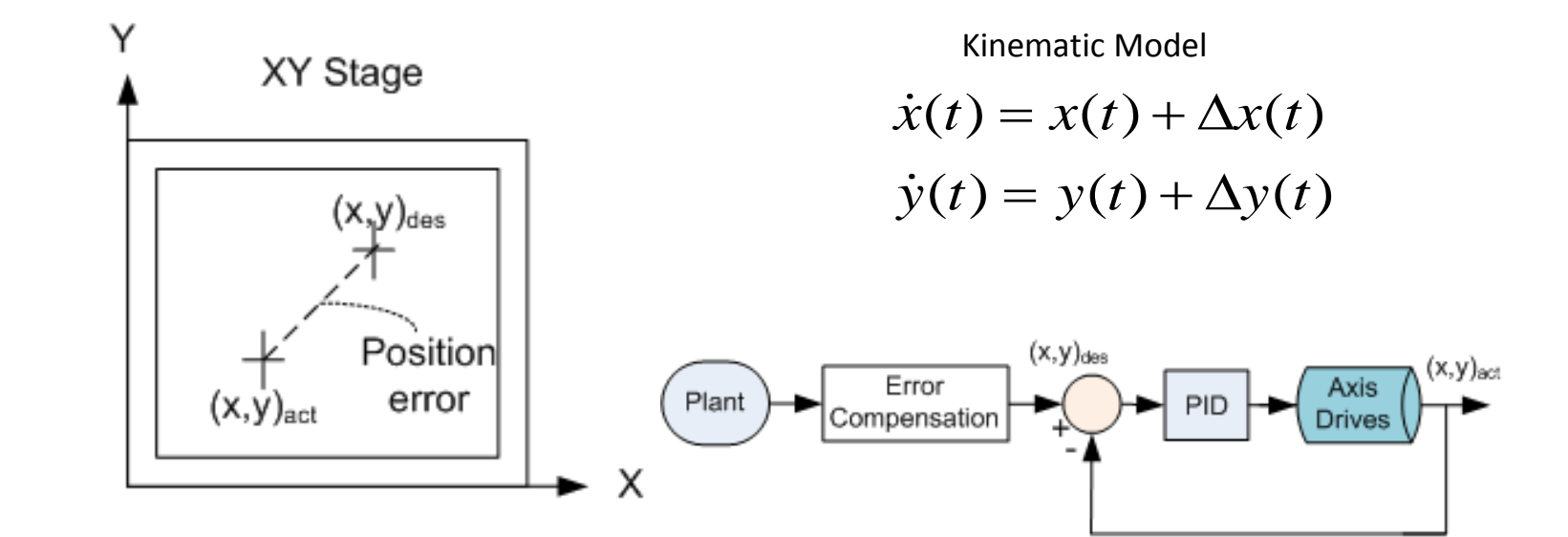

### New approach:

Error Compensation Inside the Loop

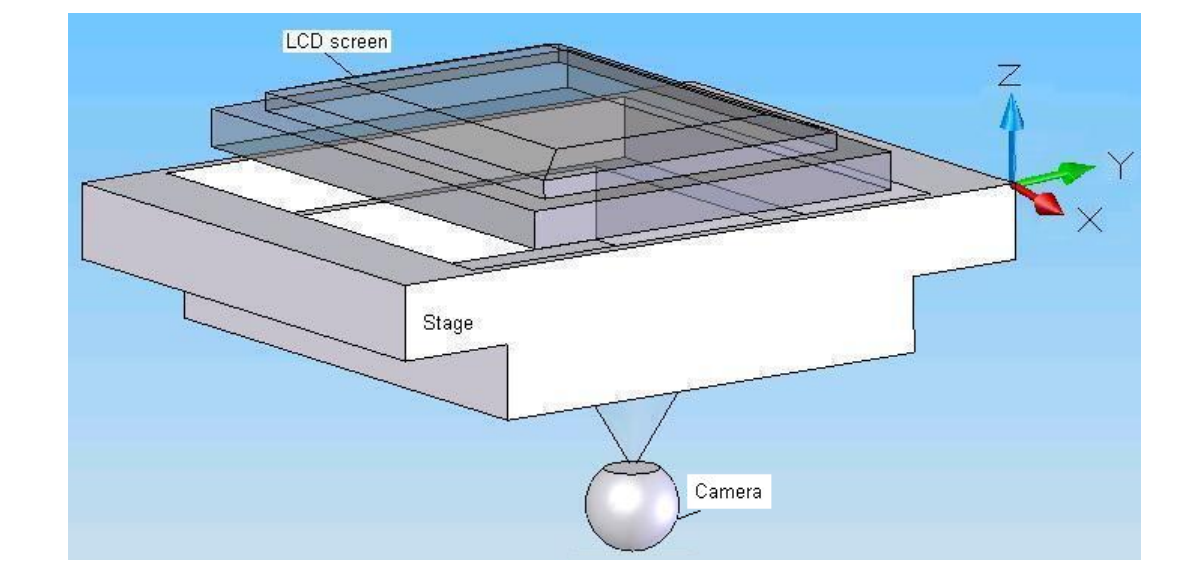
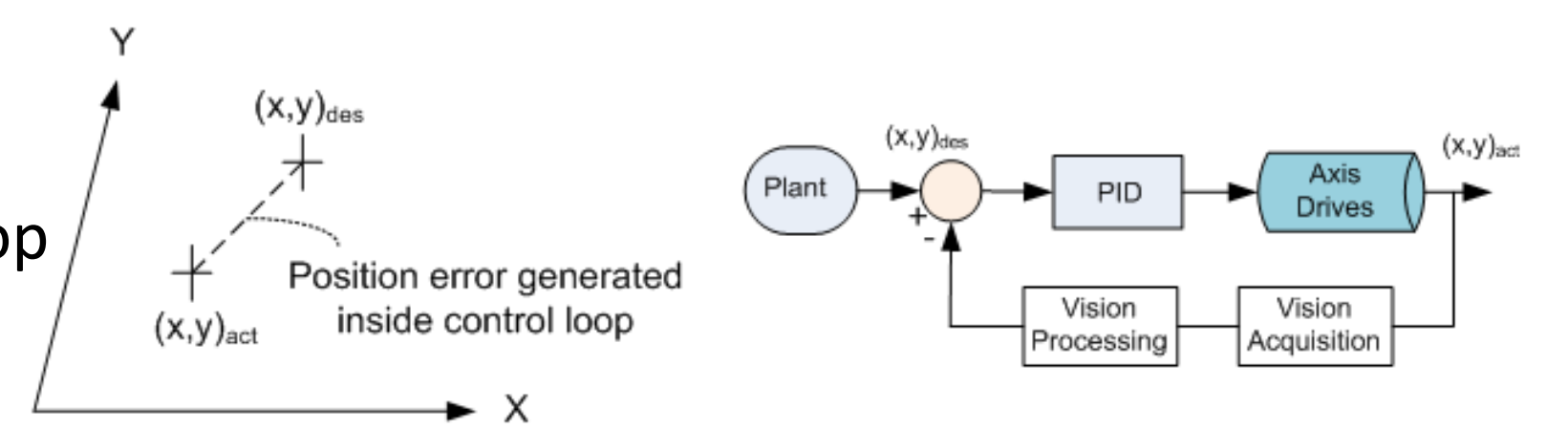

## VOXELIZATION

### Slice Part and Render to Memory

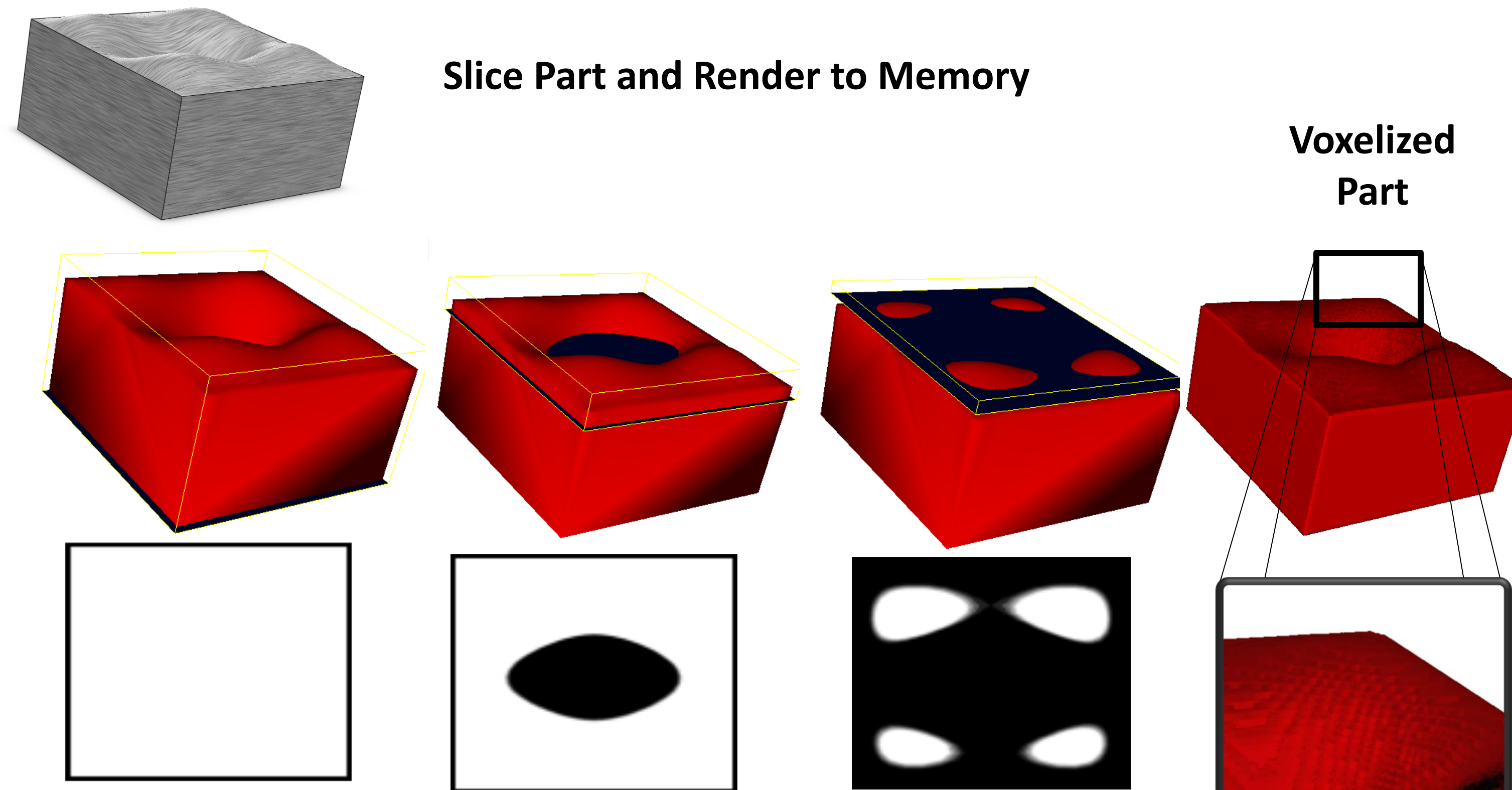

## WORK IN PROGRESS – COMPUTE INTENSIVE PATHS

### Traditional Path

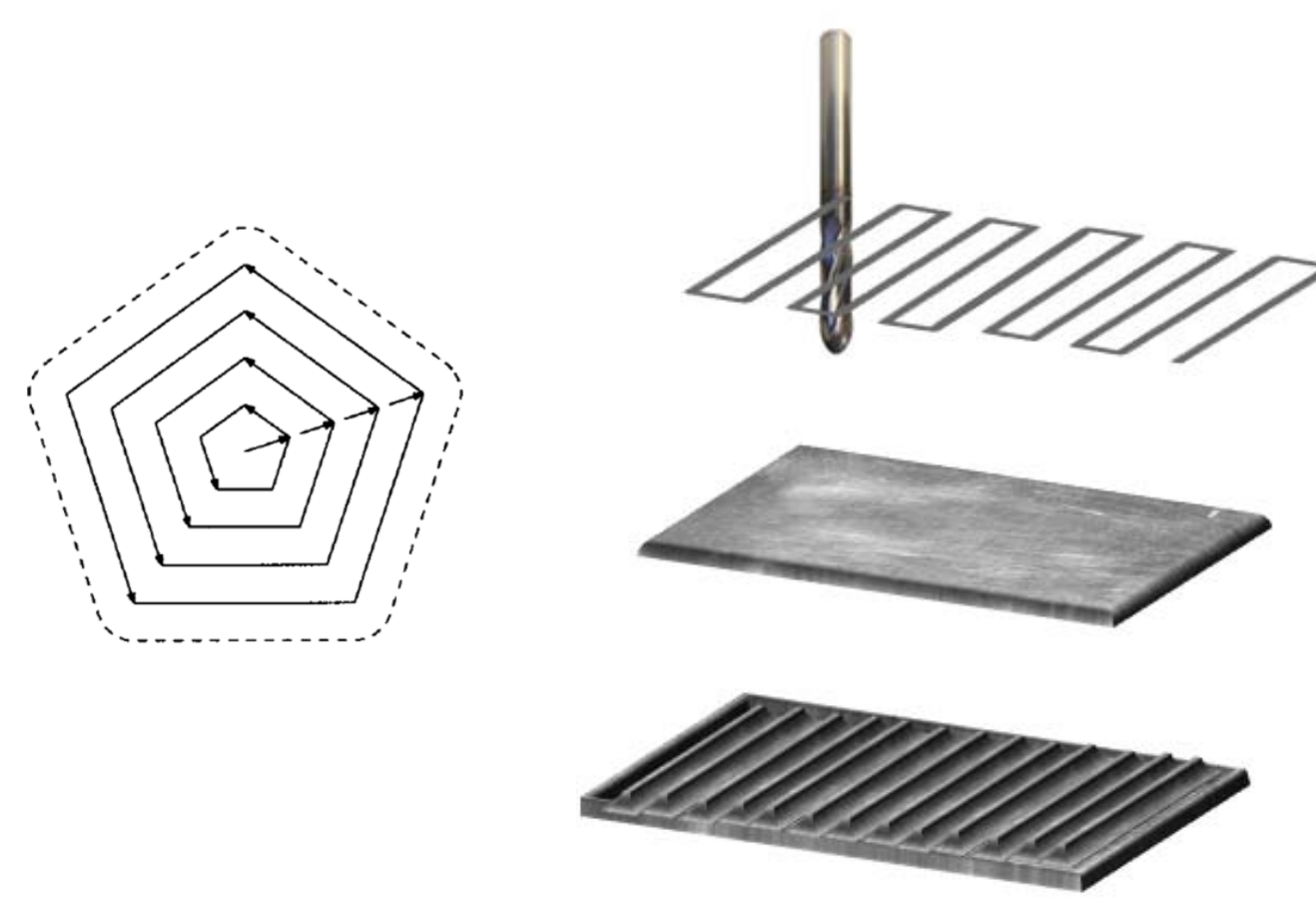

### GPU Accelerated Compute Intensive Path

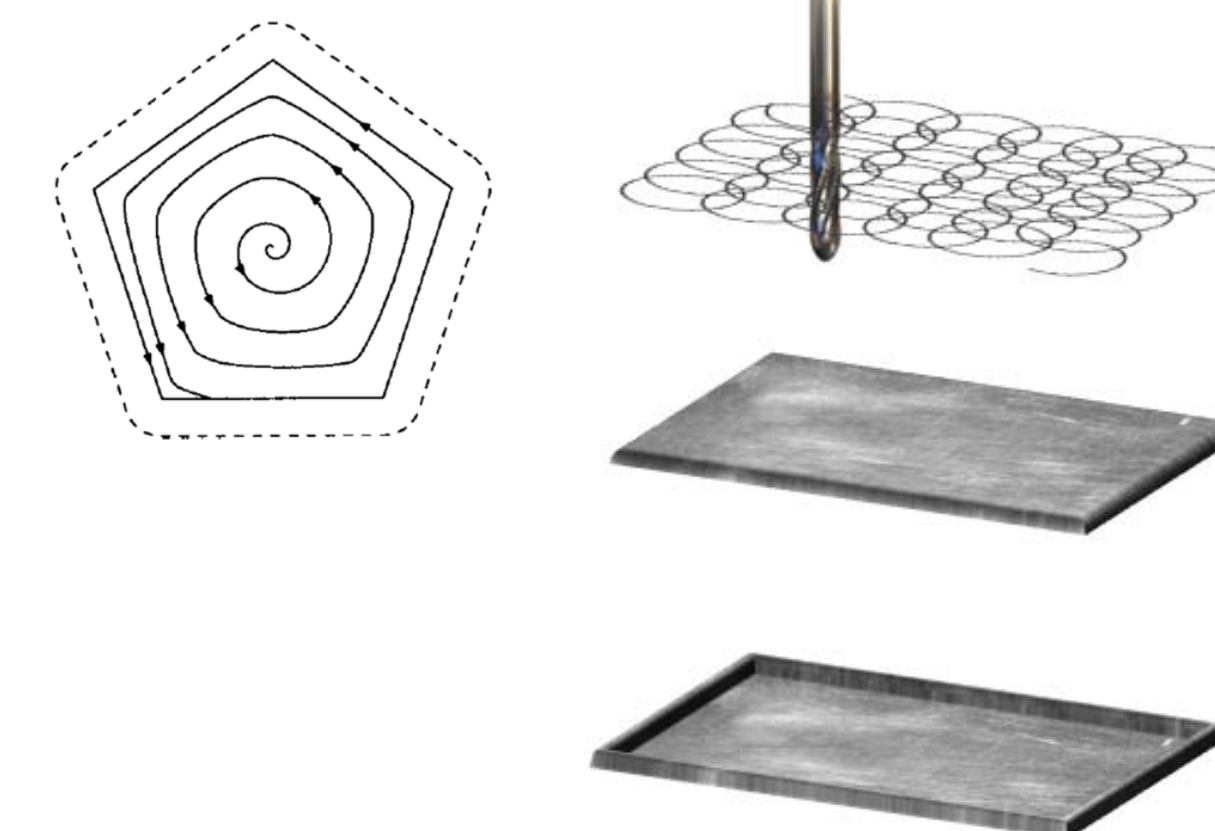

## WORK IN PROGRESS – MRI MEDICAL MOLD GENERATION OPEN ARCHITECTURE THINC INTEGRATION

### CT/MRI Bone Scan to Mold



### Local Processing

### CAD Model

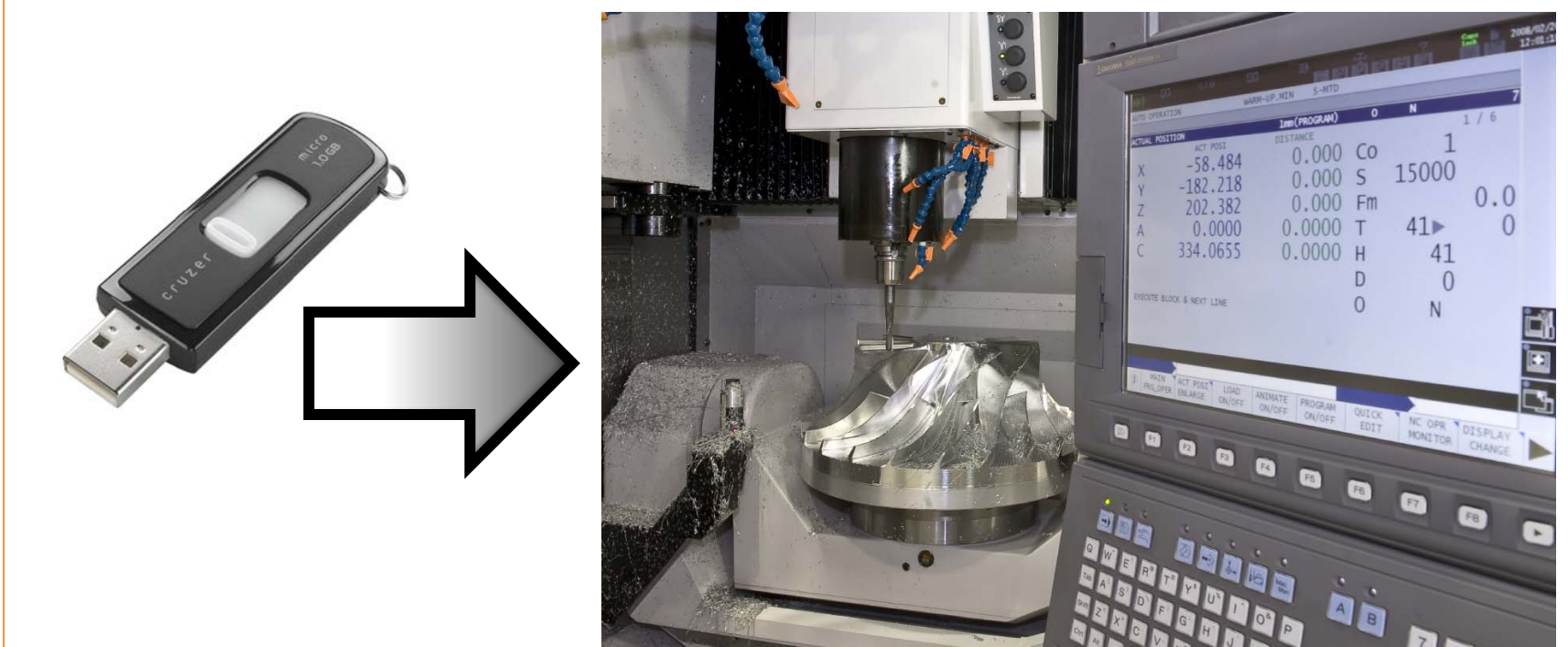

## RAY CASTING – INTERSECTION DETECTION

### Cast Rays at Voxel Model

### Use Ray Intersections w/ Part to Calculate Path and Surface Normals

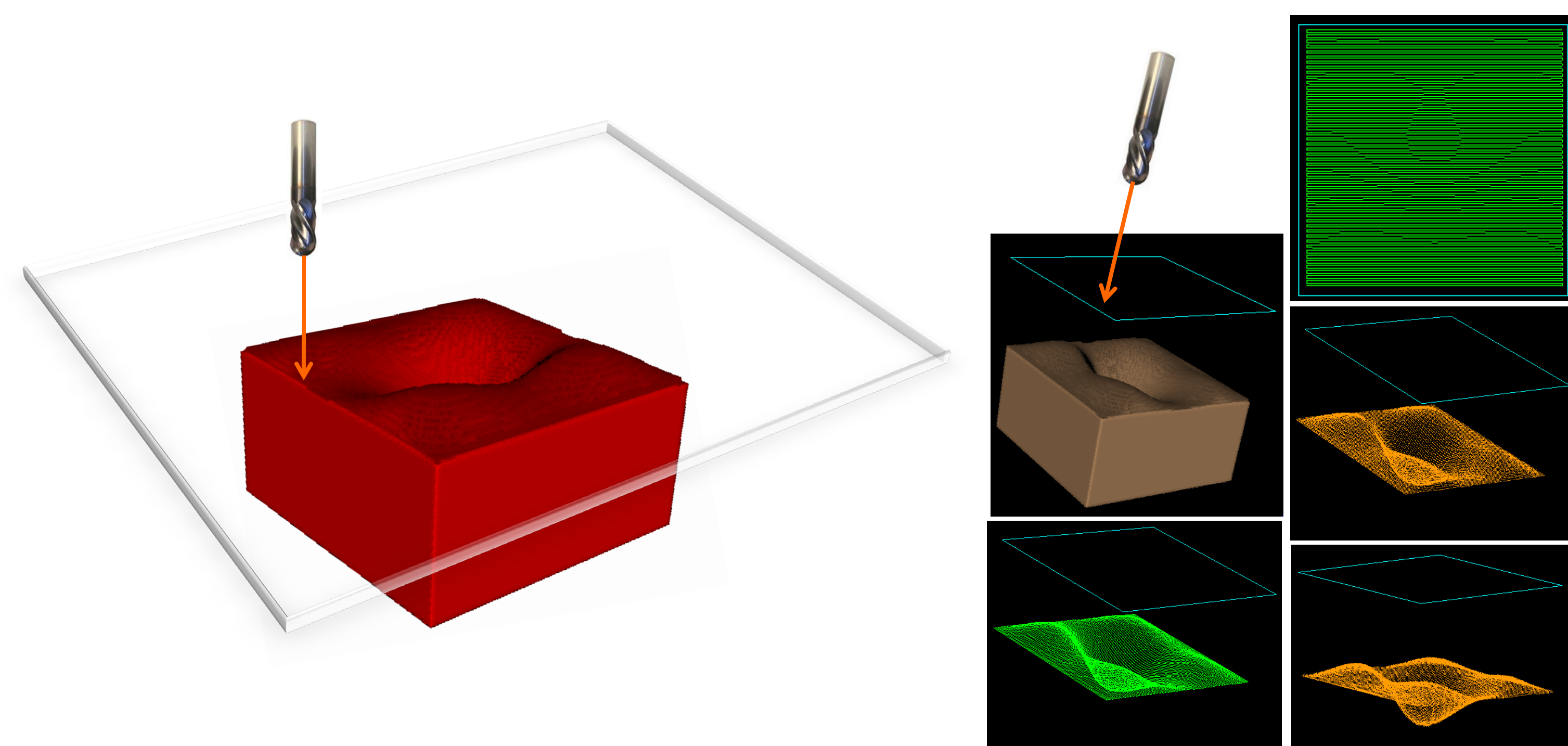

## WORK IN PROGRESS – INVERSE KINEMATIC OPTIMIZATION

### Use Error Model to Machine along Areas of maximum Kinematic Performance

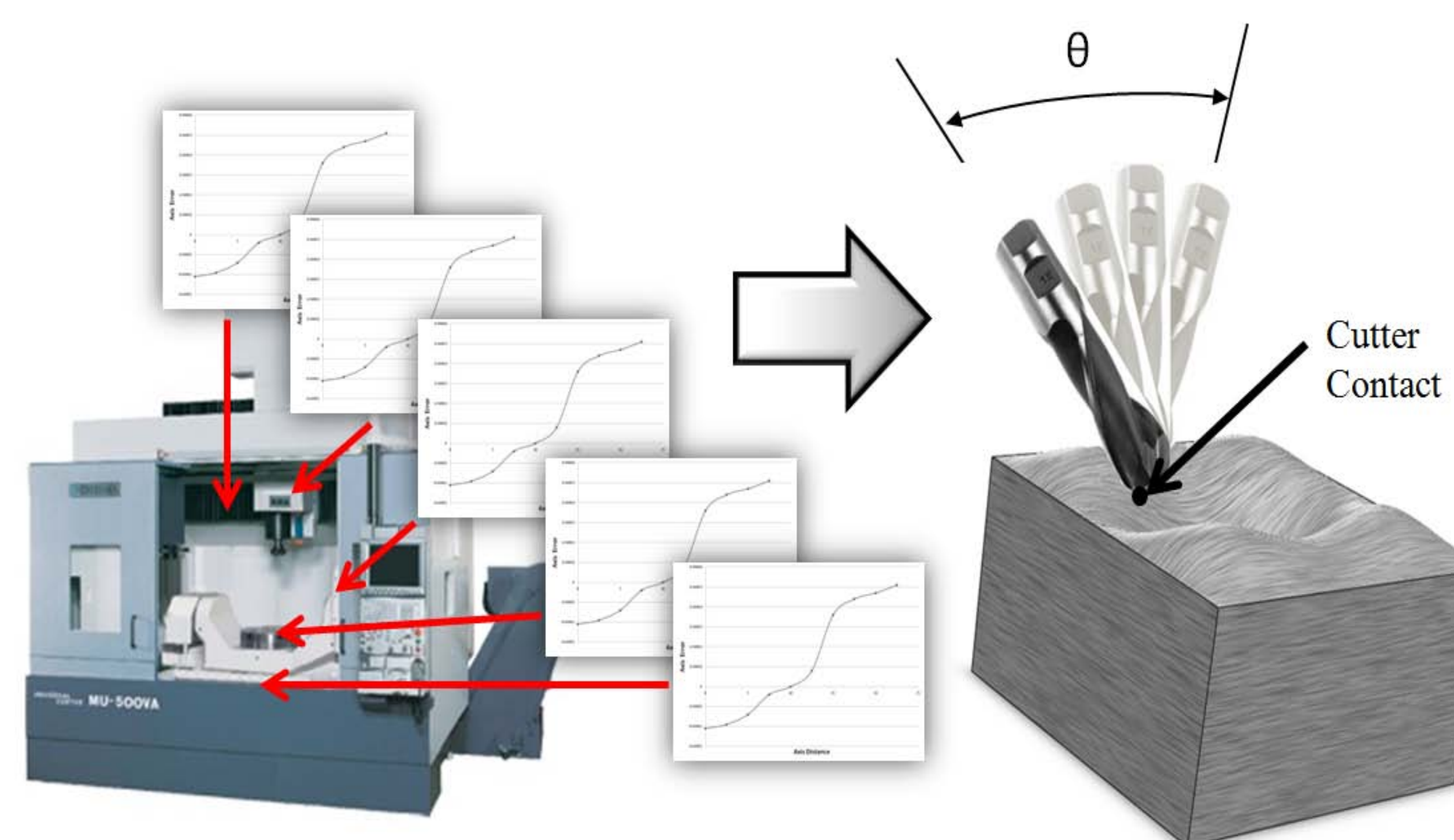

## CONCLUSIONS

In this research a ray tracing algorithm is used along with a voxel model to yield a tool trajectory. The algorithms developed are being cast into parallel problems for acceleration on the latest graphics technology. This research is currently being extended to create automatic tool paths suitable for use on GPU's embedded in commercial machine tools. This research aims at bridging the expanse that exists between the graphics and manufacturing communities by bringing the advances in graphics concepts and hardware to manufacturing research in the way of machine tool path planning. Future plans are to include machine dependent error map information and deploy graphics processing units inside of machine tools themselves to run these accelerated algorithms.

