



GEFORCE® GTX 460
GRAPHICS CARD

INSTALLATION GUIDE



nVIDIA

NVIDIA GeForce GTX 460

TABLE OF CONTENTS

Introduction	1
About this Guide	1
Minimum System Requirements	2
Unpacking	3
Equipment	3
Hardware Installation	5
Safety Instructions	5
Before You Begin	6
Installing the GeForce Graphics Card	6
Driver Installation	11
Configuring SLI	15
Accessing the NVIDIA Control Panel	15
Enabling SLI	16
Configuring HDMI	17
Enabling Audio Over HDMI	17
Features and Benefits	19
Compliance and Certifications	23

TABLE OF CONTENTS

01 INTRODUCTION

Thank you for choosing the NVIDIA® GeForce® GTX 460 graphics card.

Built from the ground up for next generation DX11 gaming, the GeForce GTX 460 delivers revolutionary tessellation performance for the ultimate gaming experience.

With full support for NVIDIA 3D Vision the GeForce GTX 460 provides the graphics horsepower and video bandwidth needed to experience games and high definition Blu-ray movies in eye-popping stereoscopic 3D.

About This Guide

This installation guide discusses the installation and operation of the NVIDIA GeForce GTX 460 graphic solution.



Note: It is important to register your product in order to receive online and phone support. Consult the registration card included in the retail packaging for more information on registering your product.

Minimum System Requirements

> **Motherboard**

PCI Express® or PCI Express 2.0-compliant motherboard with one dual-width x16 graphics slot. For a 2way SLI configuration, you need an SLI-ready motherboard with one dual-width x16 graphics slot for each graphics card.

> **System Power Supply**

Minimum 400 W (22 A on 12V rail) power supply with two 6-pin PCI Express supplementary power connector for each graphics card. For power supply recommendations for SLI configurations, visit www.slizone.com and check the Certified Products section.

> **Operating System**

- Microsoft Windows 7, 32-bit or 64-bit
- Microsoft Windows Vista, 32-bit or 64-bit
- Microsoft Windows XP, 32-bit or 64-bit
- Linux, 32-bit or 64-bit
- FreeBSD x86

> **System Memory**

1 GB system memory (2 GB recommended)

> **CD-ROM/DVD-ROM drive or internet connection for driver installation**

> **200 MB of available hard disk space**

02 UNPACKING

Prior to unpacking your new NVIDIA GeForce GTX 460 graphics card, it is important to make sure you meet all the system requirements listed on page 2 for a smooth installation.

Be sure to inspect each piece of equipment shipped in the packing box. If anything is missing or damaged, contact your reseller.

Equipment

The following equipment and documentation are included in the GeForce GTX 460 graphics card box.



NVIDIA Driver Installation CD

Contains:

- Windows 7, XP, and Vista (32/64-bit) drivers for the GeForce graphics card. For other operating systems and to keep your drivers current, visit www.nvidia.com/drivers and download the latest drivers
- Digital version of this Manual, the NVIDIA Control Panel User Guide, and Driver



Quick Start Guide

Fast and easy steps to install the GeForce graphics card(s).

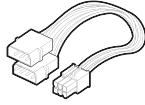

4-to-6 Pin Adapter

Use the 4-to-6 pin adapter to convert two 4-pin power supply connectors to one 6-pin connector.



Registration Card

Register to gain priority access to online and phone support.

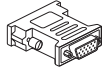

DVI-to-VGA Adapter (Optional)

Use to connect a VGA monitor to the DVI connector or a DVI monitor to the VGA connector.

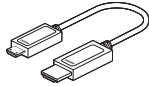

Mini-HDMI-to-HDMI Adapter (Optional)

Use to connect the mini-HDMI connector on the card to a regular size HDMI connector.

GeForce GTX 460 Graphics Card

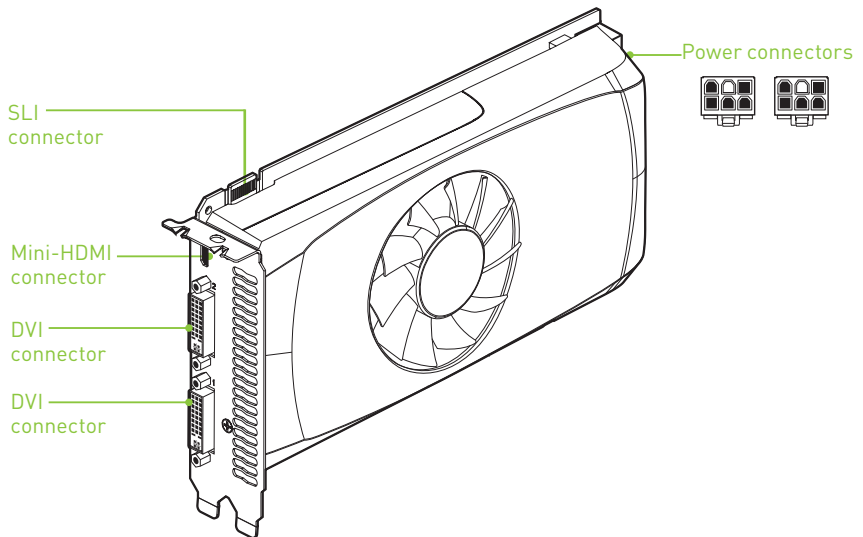

03

HARDWARE INSTALLATION

Installing the NVIDIA GeForce GTX 460 graphics card hardware involves opening up your computer. Follow all of the safety instructions provided here to ensure that there is no damage to you, your computer, or the graphics board.

Safety Instructions

To reduce the risk of fire, electric shock, or injury, always follow basic safety precautions.



Note: All hardware must be installed prior to installation of the drivers.

- > Remove power from your computer by disconnecting the AC main source before installation.
- > Do not operate this product near water or when your hands or body are wet.
- > Do not place this product on soft surfaces that could block the ventilation slots and cause overheating.
- > Do not place this product near a heating register or radiator.
- > Place this product securely on a stable surface. Serious damage to this product may result if it falls.
- > Do not allow anything to rest on the power cord. Do not place this product where a person can step or trip on the power cord.

03

Before You Begin

The GeForce GTX 460 graphics card is a PCI Express 2.0 ×16 graphics card. Your computer may already have a graphics card installed in the PCI Express slot. If so, you will need to remove that graphics card and replace it with the GeForce GTX 460 graphics card.

If you do not have a graphics card, this means that your motherboard has on-board graphics (there is a graphics chip installed on your motherboard or integrated in the motherboard chipset). If this is the case, there is no action that needs to be taken before installing your new graphics card.

Installing the GeForce Graphics Card

Because there are so many different computer systems on the market, the procedure to install the GeForce GTX 460 graphics card can vary from system to system. Use the following instructions as a guideline and consult the documentation for your computer system for any further information on your individual system.



Note: It is important that all power to the computer be disconnected before you install the graphics card.

Discharge your body's static electricity by touching a grounded surface before touching the graphics card. A grounded surface is the computer chassis, or some other surface you know to be grounded.

Use the following procedure to install the GeForce GTX 460 graphics card into your computer system.

- 1 Turn off your computer and monitor and disconnect the power cord. Depending on your computer system, you may need to disconnect the cable going to the back of your system. Mark the cables so you can make sure you reconnect them properly.
- 2 Open your computer by removing the cover/side panel. Refer to your computer documentation from the original manufacturer for assistance.

- 3 Remove any existing graphics card (if there is one). Save hardware (such as screws and brackets) to use when installing the NVIDIA graphics card.

! **Attention:** If your system has been running for a period of time prior to opening the panels, it is very important that you wait until the graphics card in your system has cooled before taking the card out of the system. Graphics card get very hot when they have been operating for any length of time.

- 4 Remove the slot cover if you do not have a graphics card installed.

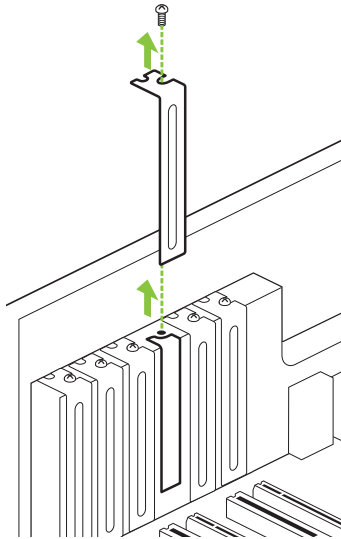

03

- 5 Plug the graphics card into the Primary PCI Express x16 slot on your motherboard. This is often the slot closest to the CPU but may be the second or third slot. Look for the slot labeled x16. It will likely be the only PCI Express slot with a retention lever on the end of the slot (or the one closest to the CPU).

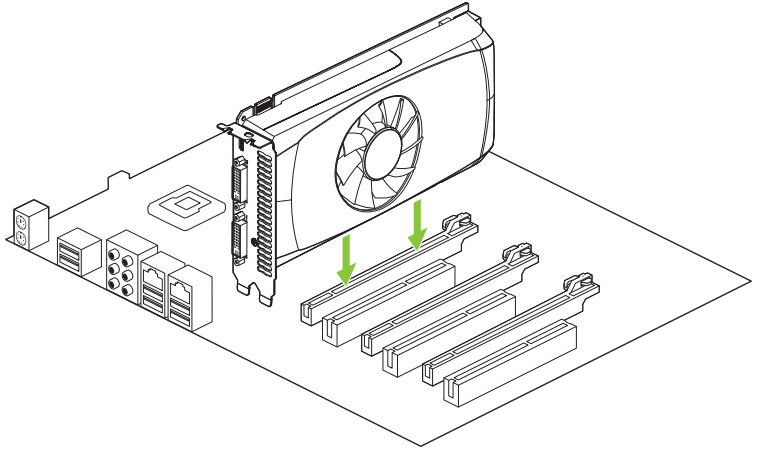

Note: It is recommended that you install the graphics card into the primary PCI Express x16 slot. If you install the graphics card into the secondary slot, your system may not recognize the graphics card and there will be nothing displayed on the monitor. Also note that on some motherboard SBIOS, the physical location of the primary slot can be configured when there are more than one PCI Express x16 slots.

If you are installing an additional GeForce GTX 460 graphics cards for an SLI configuration, continue with step 6 (2-way SLI) .



Note: All of the graphics cards in an SLI configuration must be identical.

6 Two GeForce graphic cards (2-way SLI):

- a)** Install the second GeForce card into the outer most PCI Express x16 slot on the motherboard.
- b)** Connect the two cards together using the dual SLI bridge connector that came with your SLI-ready motherboard.

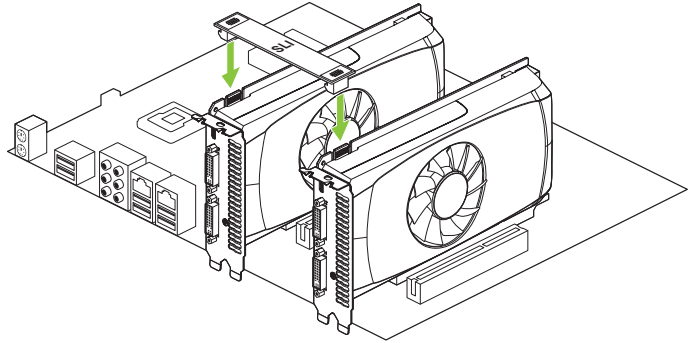

7 Connect two 6-pin PCI Express auxiliary power connectors coming from the computer power supply to the connectors on the top edge of the GeForce GTX 460 graphics card.

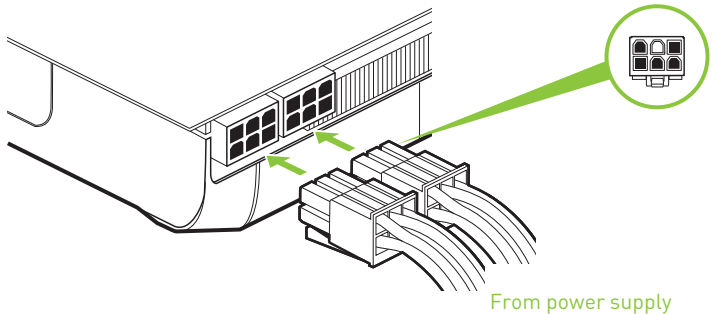

If your power supply does not have enough 6-pin power connectors, use the 4-to-6 pin adapter to convert two 4-pin power supply connectors to one 6-pin connector.

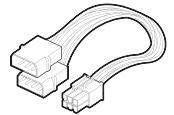

8 Reinstall the cover on your computer and reconnect any cables that you removed earlier in the installation.

03

- 9 Connect your computer monitor(s) to the GeForce graphics card using the mini-HDMI and DVI connectors. The GeForce GTX graphics card can be connected to PC monitors that support DVI, VGA, and HDMI inputs.

A single GeForce GTX 460 graphics card can support up to two displays per card in a multi-monitor configuration.

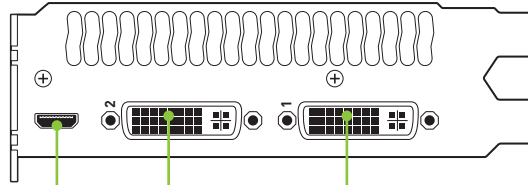

DVI connector for digital displays. Using the DVI-to-HDMI adapter, you can connect to HDTV. Using a DVI-to-VGA adapter, you can connect a second VGA display.

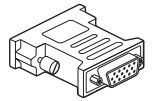

Mini-HDMI (High-Definition Multimedia Interface) Connector supports output of both video and audio from the PC to a high-definition television. Mini-HDMI is a smaller footprint version of the standard HDMI connector. A cable or adapter is needed to connect from the mini-HDMI connector to a display with a standard HDMI plug.

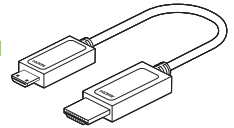

- 10 Reconnect your power cord to the PC.

04

DRIVER INSTALLATION

With the hardware installed, it is now time to install the graphics driver. NVIDIA recommends downloading and installing the most recent drivers available at:

<http://www.nvidia.com/drivers>.

Use the following procedure to load the graphics drivers.

- 1 Power up your system.
- 2 Insert the driver installation CD or double click on the GeForce driver executable file you downloaded from www.nvidia.com/drivers. The **NVIDIA Setup** program takes over and installs the drivers.

- 3 Click **Next** when the *Welcome to the InstallShield Wizard* window displays. | Click **Next** when the *Welcome to the InstallShield Wizard* window displays.

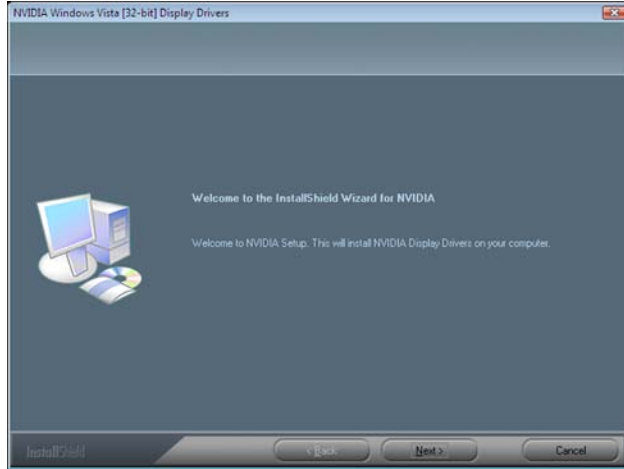

Note: It may take several minutes for the installation to take place. Your screen may go blank for a few seconds one or more times during installation. This is normal. The *Installing driver components...* screen will let you know when the installation is complete.

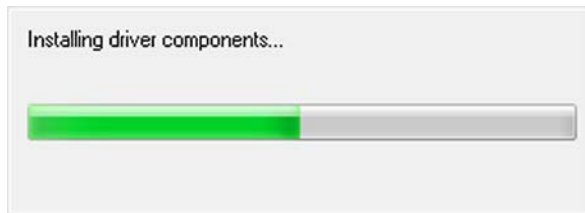

4 Select **Yes, I want to restart my computer now.**

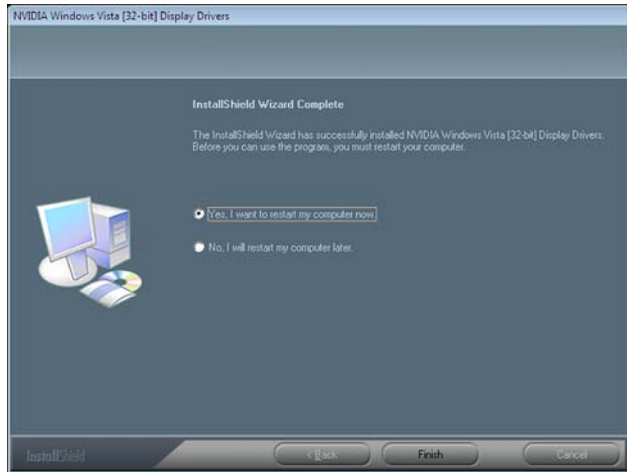

5 Click **Finish** to complete the installation and restart your system.



Note: Please visit www.nvidia.com/support to access our 24x7x365 online support system, where you can submit questions directly to our tech support staff. Questions may only be submitted in English. GeForce customers purchasing NVIDIA-branded products also have access to toll free technical support at 1-800-797-6530 from 8:00AM-5:00PM Pacific Time, M-F. The technical support line is accessible from the U.S. and Canada only.



05 CONFIGURING SLI

SLI is a revolutionary technology developed by NVIDIA that allows you to connect identical GeForce graphics cards together to deliver increased performance.

You can enable SLI by either clicking on the SLI capable system balloon in the system tray or by going to the NVIDIA Control Panel.

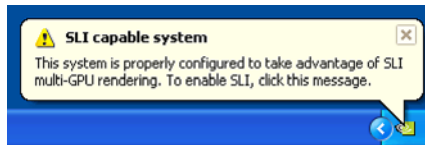

Accessing the NVIDIA Control Panel

- 1 To access the NVIDIA Control Panel, you can right-click the Windows desktop and select NVIDIA Control Panel from the menu. Other ways to access the NVIDIA Control Panel depends on the operating system.
 - > **Windows 7**
Go to **Start** → **Control Panel** → **Hardware and Sound** and select the **NVIDIA Control Panel** icon.
 - > **Windows XP**
Go to **Start** → **Control Panel** and select the **NVIDIA Control Panel** icon.

> Windows Vista

- Classic view
Go to **Start** → **Control Panel** and select the **NVIDIA Control Panel** icon.
- Control Panel Home view
Go to **Start** → **Control Panel** → **Additional Options** and select the **NVIDIA Control Panel** icon.

Enabling SLI

- 2 Once you have the NVIDIA Control Panel open, click on **Set SLI and PhysX configuration** in the left task pane.

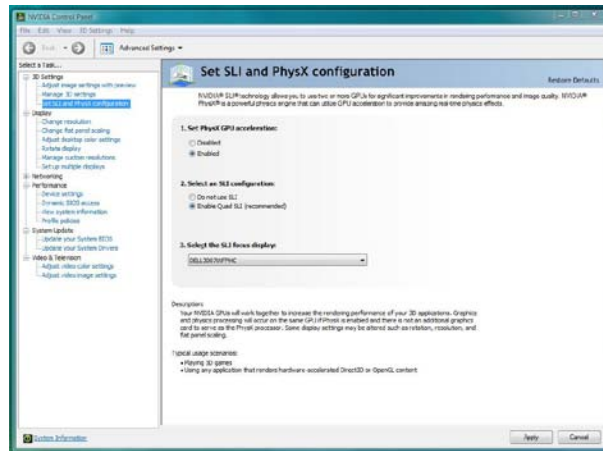

- 3 Select from the following multi-GPU configurations:
 - > **Do not use SLI**
Select this mode when you want to drive displays on each GPU.
 - > **Enable Quad SLI (recommended)**
Select this mode when you want your graphics cards to work together to increase your rendering performance and image quality.
- 4 Click **Apply**, then **Yes** on the *Applications Shutdown Required* window.

06 CONFIGURING HDMI

Connecting your HDTV via HDMI allows you to output both digital audio and video from your graphics card to an HDTV.

Enabling Audio Over HDMI

If you are connecting to your display over HDMI, you may need to set the HDMI output to be your default audio device.

In Windows 7, select **Start → Control Panel → Sound**.

On the *Playback* tab, select your HDMI display and select **Set Default**.

Congratulations! Your GeForce graphics card(s) is now ready to use!

For detailed instructions on using the NVIDIA Control Panel, consult the *Control Panel User's Guide* found on your Driver Installation CD.

You can also download the latest *Control Panel User's Guide* at

www.nvidia.com/drivers (select your driver, then click on

Documentation to download the User's Guide).

07 FEATURES

- > **Microsoft® DirectX® 11 Support:** DirectX 11 GPU with Shader Model 5.0 support designed for ultra high performance in the new API's key graphics feature, GPU-accelerated tessellation.
- > **NVIDIA CUDA™ Technology¹:** CUDA technology unlocks the power of the GPU's processor cores to accelerate the most demanding tasks such as video transcoding, physics simulation, ray tracing, and more, delivering incredible performance improvements over traditional CPUs.
- > **NVIDIA PhysX® Technology²:** GeForce GPU support for NVIDIA PhysX technology, enabling a totally new class of physical gaming interaction for a more dynamic and realistic experience with GeForce.
- > **NVIDIA® 3D Vision™ Ready:** GeForce GPU support for NVIDIA 3D Vision, bringing a fully immersive stereoscopic 3D experience to the PC. A combination of high-tech wireless glasses and advanced software, 3D Vision transforms hundreds of PC games into full stereoscopic 3D. In addition, you can watch 3D movies and 3D digital photographs in eye popping, in crystal-clear quality.
- > **NVIDIA® 3D Vision™ Surround Ready³:** Expand your games across three displays in full stereoscopic 3D for the ultimate "inside the game" experience with the power of NVIDIA 3D Vision and SLI technologies. NVIDIA® Surround™ also supports triple screen gaming with non-stereo displays.
- > **GigaThread™ Technology:** Massively multi-threaded architecture supports thousands of independent, simultaneous threads, pro
- > **Microsoft Windows 7 Support:** Windows 7 is the next generation operating system that will mark a dramatic improvement in the way the OS takes advantage of the graphics processing unit

(GPU) to provide a more compelling user experience. By taking advantage of the GPU for both graphics and computing, Windows 7 will not only make today's PCs more visual and more interactive but also ensure that they have the speed and responsiveness customers want.

- > **DirectCompute Support:** Full support for DirectCompute, Microsoft's GPU computing API.
- > **OpenCL Support:** Full support for OpenCL GPU computing API.
- > **32x Anti-aliasing Technology:** Lightning fast, high-quality anti-aliasing at up to 32x sample rates obliterates jagged edges.
- > **NVIDIA® GeForce® Unified Driver Architecture (UDA):** Delivers a proven record of compatibility, reliability, and stability with the widest range of games and applications. NVIDIA® GeForce® drivers provide the best out-of-box experience for every user and deliver continuous performance and feature updates over the life of NVIDIA GeForce® GPUs.
- > **PCI Express 2.0 Support :** Designed for the new PCI Express 2.0 bus architecture offering the highest data transfer speeds for the most bandwidth-hungry games and 3D applications, while maintaining backwards compatibility with existing PCI Express motherboards for the broadest support.
- > **Dual-link DVI Support:** Able to drive industry's largest and highest resolution flat-panel displays up to 2560x1600 and with support for High-bandwidth Digital Content Protection (HDCP).
- > **HDMI 1.3a support:** Fully integrated support for HDMI 1.3a including xvYCC, deep color, and 7.1 digital surround sound including Dolby TrueHD and DTS-HD. Upgradeable to HDMI 1.4 support for 3D formats with upcoming NVIDIA 3DTV Play software. Refer to <http://www.nvidia.com/3dtv> for more details.
- > **NVIDIA PureVideo® HD Technology⁴ :** The combination of high-definition video decode acceleration and post-processing that delivers unprecedented picture clarity, smooth video, accurate color, and precise image scaling for movies and video.
 - **Hardware Decode Acceleration:** Provides ultra-smooth playback of H.264, VC-1, WMV, DivX, MPEG-2 and MPEG-4 HD and SD movies without the need for a dual or quad-core CPU.
 - **Dual-stream Hardware Acceleration:** Supports picture-in-picture content for the ultimate interactive Blu-ray and HD DVD movie experience.

- **Dynamic Contrast Enhancement & Color Stretch:** Dynamically provides post-processing and optimization of High Definition movies for spectacular picture clarity.
- **Dual-link HDCP Capable**⁵: Designed to meet the output protection management (HDCP) and security specifications of the Blu-ray Disc format, allowing the playback of encrypted movie content on PCs when connected to HDCP-compliant displays
- **Enhanced Error Resilience:** Correct errors or losses in broadcast content to ensure crisp, high quality playback.
- **Advanced Spatial-Temporal De-Interlacing:** Sharpens HD and standard definition interlaced content on progressive displays, delivering a crisp, clear picture that rivals high-end home-theater systems.
- **High-Quality Scaling:** Enlarges lower resolution movies and videos to HDTV resolutions, while maintaining a clear, clean image. Also provides downscaling of videos, including high-definition, while preserving image detail.
- **Inverse Telecine (3:2 & 2:2 Pulldown Correction):** Recovers original film images from films-converted-to-video (DVDs, 1080i HD content), providing more accurate movie playback and superior picture quality.
- **Bad Edit Correction:** When videos are edited, the edits can disrupt the normal 3:2 or 2:2 pulldown cadence. PureVideo uses advanced processing techniques to detect poor edits, recover the original content, and display perfect picture detail frame after frame for smooth, natural looking video.
- **Noise Reduction:** Improves movie image quality by removing unwanted artifacts.
- **Edge Enhancement:** Sharpens movie images by providing higher contrast around lines and objects.

1. Requires application support for CUDA technology.

2. NVIDIA PhysX drivers are required to experience in-game GPU PhysX acceleration. Refer to www.nvidia.com/PhysX for more information.

3. NVIDIA 3D Vision Surround requires appropriate NVIDIA driver, two or more graphics cards in NVIDIA SLI configuration, 3D Vision glasses and three matching 3D Vision-Ready displays. See www.nvidia.com/surround for more information.

4. Feature requires supported video software. Features may vary by product.

5. Requires other HDCP-compatible components

07

COMPLIANCES

- > Australian Communications Authority (C-Tick), Class B
- > Bureau of Standards, Metrology, and Inspection (BSMI), Class B
- > Conformité Européenne (CE), Class B
- > Federal Communications Commission (FCC) - Class B
- > Industry Canada (ICES-003), Class B
- > Korean Communications Commission (KCC), Class B
- > Underwriters Laboratories (UL, cUL)
- > Voluntary Control Council for Interference (VCCI), Class B
- > ISO9247-307 VDT Ergonomics



Notice

ALL NVIDIA DESIGN SPECIFICATIONS, REFERENCE BOARDS, FILES, DRAWINGS, DIAGNOSTICS, LISTS, AND OTHER DOCUMENTS (TOGETHER AND SEPARATELY, "MATERIALS") ARE BEING PROVIDED "AS IS." NVIDIA MAKES NO WARRANTIES, EXPRESSED, IMPLIED, STATUTORY, OR OTHERWISE WITH RESPECT TO THE MATERIALS, AND EXPRESSLY DISCLAIMS ALL IMPLIED WARRANTIES OF NON-INFRINGEMENT, MERCHANTABILITY, AND FITNESS FOR A PARTICULAR PURPOSE.

Information furnished is believed to be accurate and reliable. However, NVIDIA Corporation assumes no responsibility for the consequences of use of such information or for any infringement of patents or other rights of third parties that may result from its use. No license is granted by implication or otherwise under any patent or patent rights of NVIDIA Corporation. Specifications mentioned in this publication are subject to change without notice. This publication supersedes and replaces all information previously supplied. NVIDIA Corporation products are not authorized for use as critical components in life support devices or systems without express written approval of NVIDIA Corporation.

FCC

This equipment has been tested and found to comply with the limits for a Class B digital device, pursuant to Part 15 of the FCC Rules. These limits are designed to provide reasonable protection against harmful interference in a residential installation. This equipment generates, uses, and can radiate radio frequency energy and, if not installed and used in accordance with the instructions, may cause harmful interference to radio communications. However, there is no guarantee that interference will not occur in a particular installation.

If this equipment does cause harmful interference to radio or television reception, which can be determined by turning the equipment off and on, the user is encouraged to try to correct the interference by one or more of the following measures:

- > Reorient or relocate the receiving antenna.
- > Increase the separation between the equipment and receiver.
- > Connect the equipment into an outlet on a circuit different from that to which the receiver is connected.
- > Consult the dealer or an experienced radio/TV technician for help.

Trademarks

NVIDIA, the NVIDIA logo, CUDA, GeForce, GigaThread, Lumenex, PureVideo, and PhysX Technology are trademarks or registered trademarks of NVIDIA Corporation. Other company product names may be trademarks of the respective companies with which they are associated.

Copyright

© 2010 NVIDIA Corporation. All rights reserved.

