



# TESLA C1060 COMPUTING PROCESSOR BOARD

BD-04111-001\_v06 | January 2010

## Board Specification



## DOCUMENT CHANGE HISTORY

BD-04111-001\_v06

Version	Date	Authors	Description of Change
01	July 10, 2008	SG, SM	Preliminary Release
02	July 15, 2008	SG, SM	Minor text updates Updated <i>Support Information</i> section
03	September 22, 2008	SG, SM	Initial Release Updated thermal information Minor text updates
04	December 8, 2008	SG, SM	Updated fan flow and power information
05	January 22, 2009	SG, SM	Updated board power
06	January 26, 2010	RK, SM	Updated document look and feel Updated storage temperature (Table 10)

# TABLE OF CONTENTS

<b>Overview</b> .....	<b>1</b>
Key Features .....	1
Computing Processor Description .....	2
Configuration .....	3
<b>Mechanical Specifications</b> .....	<b>4</b>
PCI Express System .....	4
Standard I/O connector Placement .....	5
Internal Connectors and Headers .....	6
External PCI Express Power Connectors .....	6
4-Pin Fan Connector .....	9
<b>Power Specifications</b> .....	<b>11</b>
Power by Rail .....	12
<b>Thermal Specifications</b> .....	<b>13</b>
thermal Qualification Summary .....	13
Cooling Solution .....	15
<b>Support Information</b> .....	<b>17</b>
Certificates and Agencies .....	17
Agencies .....	17
Languages .....	18

## LIST OF FIGURES

Figure 1.	Tesla C1060 Block Diagram .....	2
Figure 2.	Tesla C1060 Computing Processor Board .....	4
Figure 3.	Tesla C1060 Bracket (No Connectors) .....	5
Figure 4.	6-Pin PCI Express Power Connector .....	7
Figure 5.	8-Pin PCI Express Power Connector .....	8
Figure 6.	4-Pin Fan Connector .....	10
Figure 7.	TM72 Active Fan Sink .....	15

## LIST OF TABLES

Table 1.	Board Configuration.....	3
Table 2.	6-Pin PCI Express Power Connector Pinout .....	9
Table 3.	8-Pin PCI Express Power Connector Pinout .....	9
Table 4.	4 Wire Thermal Control Pinout .....	10
Table 5.	Configuration with External PCI Express Connectors.....	11
Table 6.	Power by Rail .....	12
Table 7.	Test Setup and Configuration.....	14
Table 8.	Sample Thermal Results and Specification .....	14
Table 9.	Fan Specifications and Conditions .....	16
Table 10.	Environmental Specifications and Conditions .....	16
Table 11.	Languages Supported .....	18

# OVERVIEW

The NVIDIA® Tesla™ C1060 computing processor board is a PCI Express 2.0 full-height (4.376 inches by 10.50 inches) form factor computing add-in card based on the NVIDIA Tesla T10 graphics processing unit (GPU). This board is targeted as high-performance computing (HPC) solution for PCI Express systems.

The Tesla C1060 is capable of 933 GFLOPs/s of processing performance and comes standard with 4 GB of GDDR3 memory at 102 GB/s bandwidth.

## KEY FEATURES

### GPU

- ▶ Number of processor cores: 240
- ▶ Processor core clock: 1.296 GHz
- ▶ Voltage: 1.1875 V
- ▶ Package size: 45.0 mm × 45.0 mm 2236-pin flip-chip ball grid array (FCBGA)

### Board

- ▶ Fourteen layer printed circuit board (PCB)
- ▶ PCI Express 2.0 ×16 system interface
- ▶ Physical dimensions: 4.376 inches × 10.50 inches, dual slot
- ▶ Board power dissipation: 187.8 W

### External Connectors

- ▶ None

### Internal Connectors and Headers

- ▶ One 6-pin PCI Express power connector
- ▶ One 8-pin PCI Express power connector
- ▶ 4-pin fan connector

### Memory

- ▶ 800 MHz
- ▶ 512-bit memory interface
- ▶ 4 GB: Thirty-two pieces 32M × 32 GDDR3 136-pin BGA, SDRAM

### BIOS

- ▶ 1 Mbit Serial ROM

## COMPUTING PROCESSOR DESCRIPTION

Figure 1 is a block diagram of the Tesla C1060 computing processor.

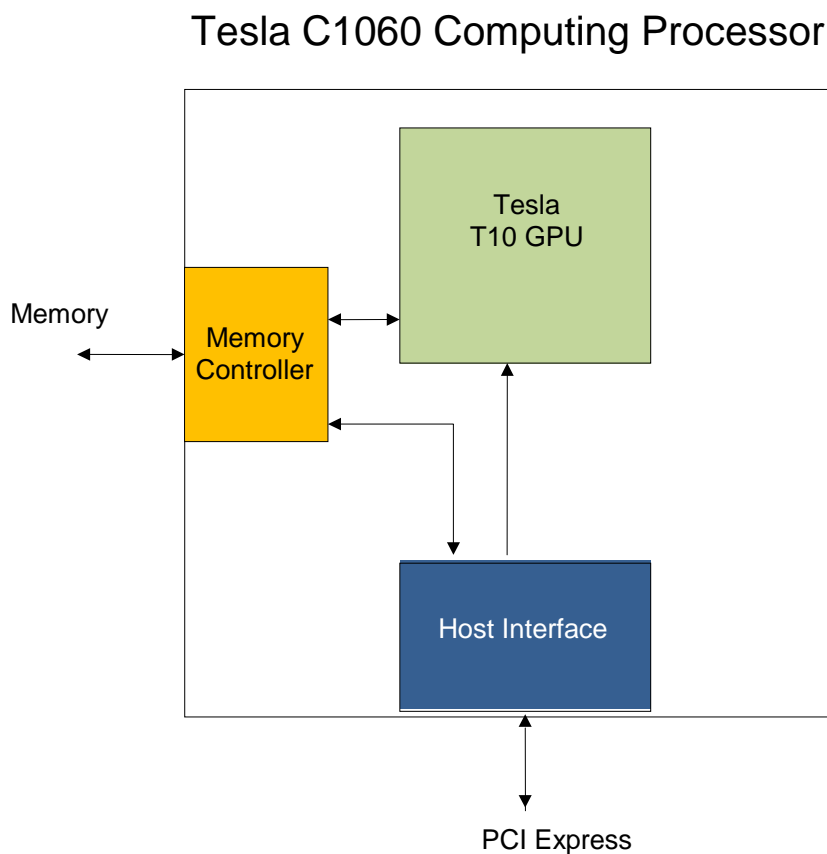

Figure 1. Tesla C1060 Block Diagram

## CONFIGURATION

There is one configuration available (Table 1) for the Tesla C1060 board.

Table 1. Board Configuration

Specification	Description
Generic SKU reference	900-20607-0000-000
Chip	Tesla T10 GPU
Package size: GPU	45.0 mm x 45.0 mm
Processor clock	1296 MHz
Memory clock	800 MHz
Memory size	4 GB
Memory I/O	512-bit GDDR3
Memory configuration	32 pcs 32M x 32 GDDR3 SDRAM
External connectors	None
Internal connectors and headers	8-pin PCI Express power connector 6-pin PCI Express power connector 4-pin fan connector
Board power	187.8 W (idle power = 57.65 W)
Thermal cooling solution	TM72 active fan sink

# MECHANICAL SPECIFICATIONS

## PCI EXPRESS SYSTEM

The Tesla C1060 computing processor board (Figure 2) conforms to the PCI Express full height (4.376 inches by 10.50 inches) form factor.



Figure 2. Tesla C1060 Computing Processor Board



## STANDARD I/O CONNECTOR PLACEMENT

As shown in Figure 3, the Tesla C1060 does not include any external I/O connectors.



Figure 3. Tesla C1060 Bracket (No Connectors)

## INTERNAL CONNECTORS AND HEADERS

The Tesla C1060 board supports the following internal connectors and headers.

- ▶ 8-pin PCI Express power connector (can be used with a 6-pin power cable)
- ▶ 6-pin PCI Express power connector
- ▶ 4-pin fan connector

## External PCI Express Power Connectors

The Tesla C1060 is a performance-optimized, high-end board and utilizes power from the PCI Express connector as well as external power connectors. The board can be used in two different ways.

- ▶ One 8-pin PCI Express power connector or
- ▶ Two 6-pin PCI Express power connectors



**Note:** When connecting two 6-pin power cables to the two power connectors on the Tesla C1060 board, ensure that both power cables come from the same power rail. For example, the same 12 V power supply.

Figure 4 and Figure 5 show the specifications, and Table 2 and Table 3 show the pinouts for the 6-pin and 8-pin external PCI Express power connectors, respectively.

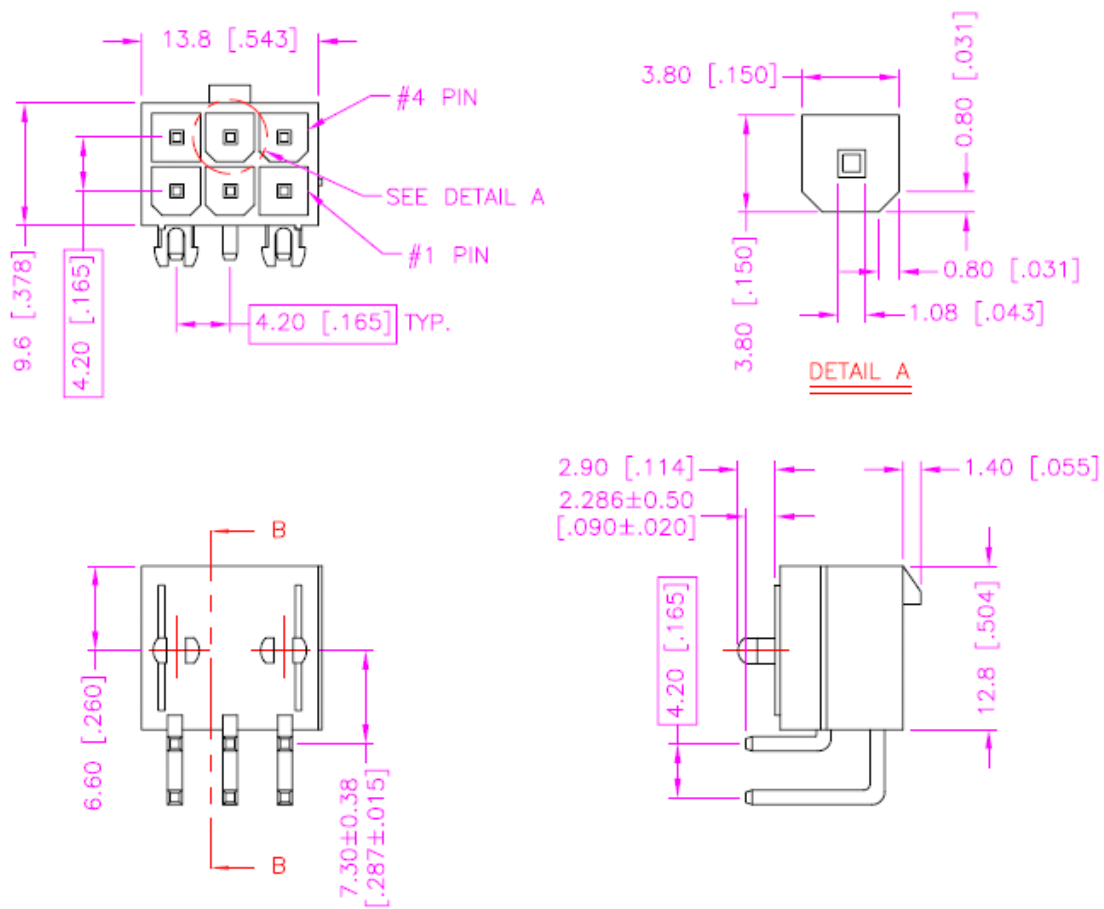

Figure 4. 6-Pin PCI Express Power Connector

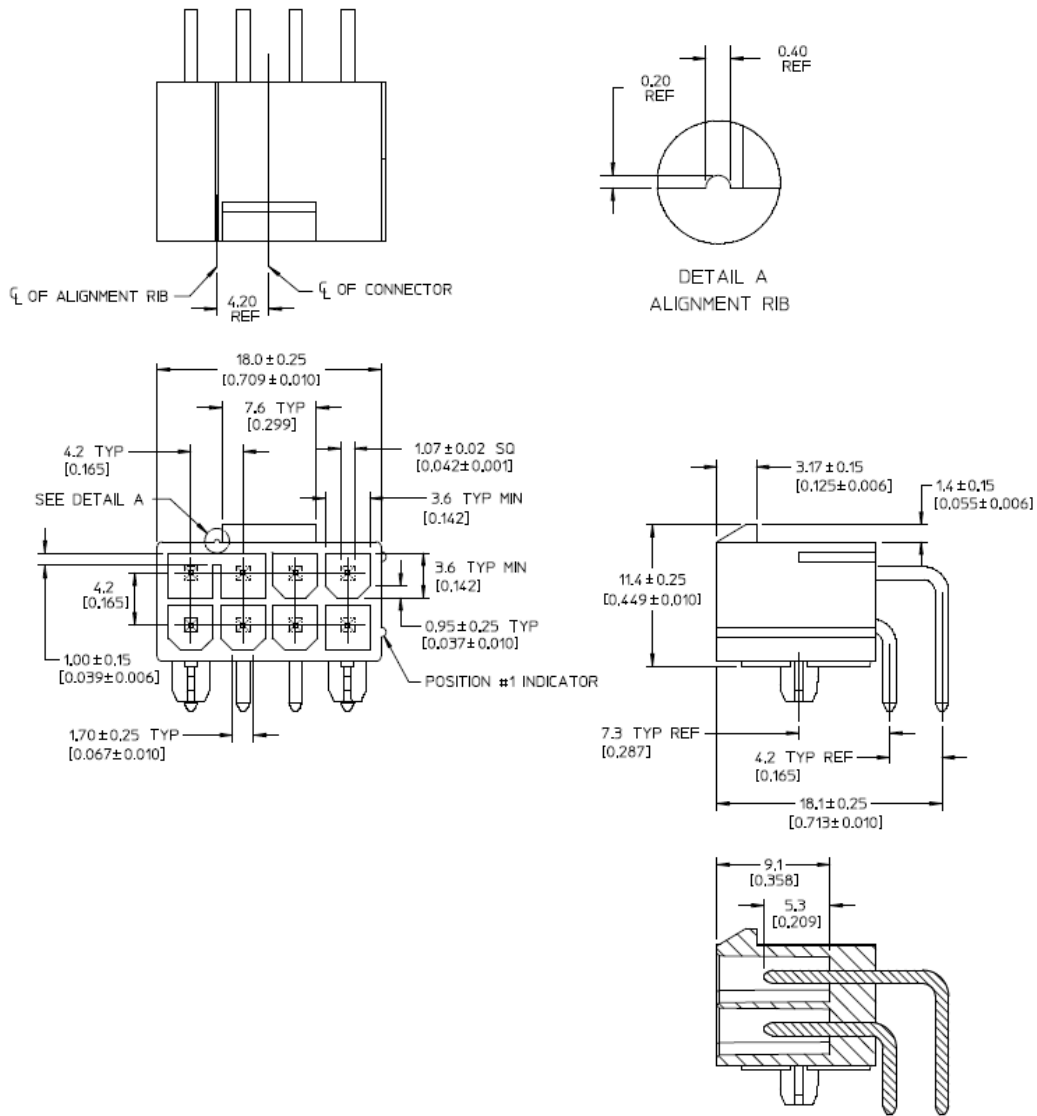

Figure 5. 8-Pin PCI Express Power Connector

Table 2. 6-Pin PCI Express Power Connector Pinout

Pin Number	Description
1	+12 V
2	+12 V
3	+12 V
4	GND
5	Sense
6	GND

Table 3. 8-Pin PCI Express Power Connector Pinout

Pin Number	Description
1	+12 V
2	+12 V
3	+12 V
4	Sense1
5	GND
6	Sense0
7	GND
8	GND

## 4-Pin Fan Connector

The Tesla C1060 board uses a 4-pin fan to control the fan speed of the thermal solution. The details of the connector (P/N: PH-T-4) are given in Figure 6. This part is a 2.0 mm (0.079") pitch disconnectable connector.

Table 4 lists the pin assignments for this connector.

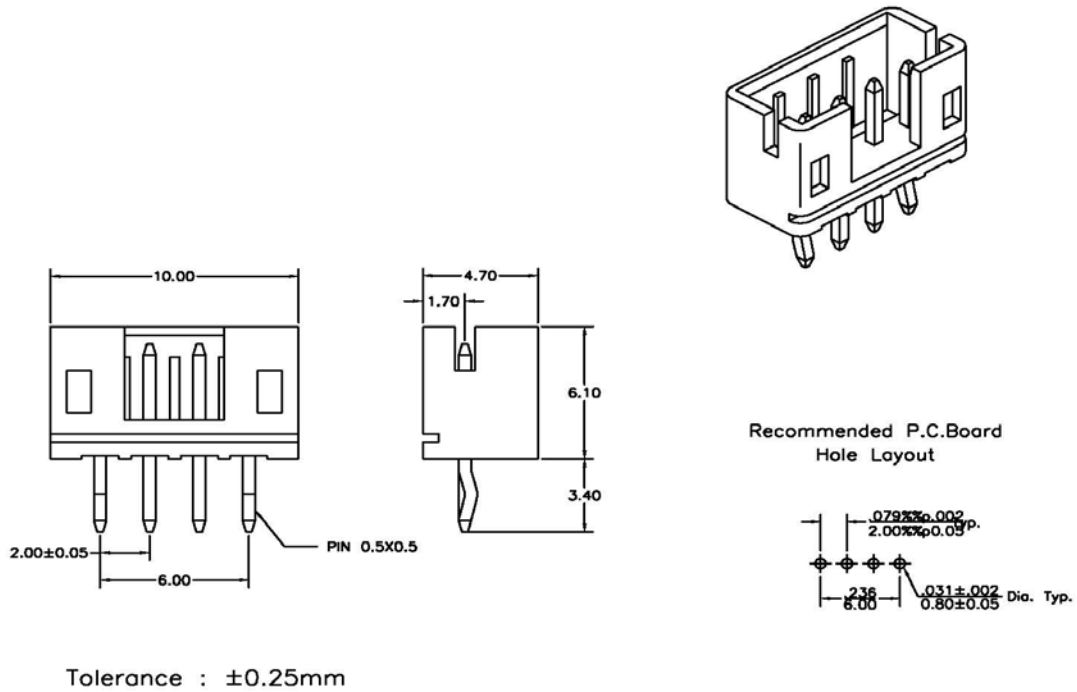

**Specifications:**

- Current Rating : 2A AC, DC
- Voltage Rating : 250V AC, DC
- Temperature Range : -40°C to +105°C
- Contact Resistance : Initial Value/10 mΩ Max.  
After Environmental Testing /20 mΩ Max.
- Insulation Resistance : 1000 MΩ Min.
- Withstand Voltage : 1500 VAC/Minute
- RoHs compliant.

**Features:**

- **Wafer**
- Model No. : PH-T-4
- Circuits : 4
- Material : Post : Brass Tin/Plated  
Base : Nylon 66, UL94V-0
- P.C.Board Thickness : 1.6mm(.063")

Figure 6. 4-Pin Fan Connector

Table 4. 4 Wire Thermal Control Pinout

Pin Number	Description
1	PWM (to fan)
2	TACH (from fan)
3	+12 V
4	GND

# POWER SPECIFICATIONS

The Tesla C1060 computing processor is a performance optimized high-end board solution. Power is taken from the PCI Express host bus as well as either one 8-pin or two 6-pin PCI Express power connectors.



**Note:** When connecting two 6-pin power cables to the two power connectors on the Tesla C1060 board, ensure that both power cables come from the same power rail. For example, the same 12 V power supply.

Without auxiliary power provided to the Tesla C1060 board, the board will not boot and LED lights on the board will light up as listed in Table 5. This table outlines the different possible scenarios as well as the resulting behaviors.

Table 5. Configuration with External PCI Express Connectors

8-Pin Power Connector	6-Pin Power Connector	Result
Connected (either 8-pin or 6-pin)	Connected	Full Power - LED light on the bracket is <b>GREEN</b> by default
8-pin connected	Not connected	Full Power - LED light on the bracket is <b>GREEN</b> by default
6-pin connected	Not connected	LED light is <b>RED</b> - board will not boot to OS
Not connected	Connected	LED light is <b>RED</b> - board will not boot to OS
Not connected	Not connected	LED light is <b>RED</b> - board will not boot

## POWER BY RAIL

Table 6 lists the power by rail numbers for the Tesla C1060 board.

Table 6. Power by Rail

PEX12V	PEX3V3	EX12V	Total Board Power
62.01	2.82	124.25	187.82 W
8-pin connected	Not connected	Full Power - LED light on the bracket is GREEN by default	



# THERMAL SPECIFICATIONS

## THERMAL QUALIFICATION SUMMARY

The information contained in this summary report is intended to provide users of the Tesla C1060 computing processor with thermal information necessary to assist in thermal management efforts. This information is not intended to provide a specific thermal management solution. However, it does show an approach that result in the reliable operation of the Tesla C1060.

The product and cooling solutions used are:

- ▶ Device product: Tesla C1060 board
- ▶ Cooling solution: Fan sink solution, Cooler Master TM72 NV P/N: 580-10607-2000-000. The cooling solution assembly includes a heat sink, fan, backplate, thermal grease interface material, and screws.
- ▶ Result: Under the operating conditions described in the following tables, the Tesla C1060 passed thermal qualification.

Table 7. Test Setup and Configuration

System Part	Configuration
PC	Motherboard attached to a chassis frame - entire unit placed in an acrylic box
Motherboard	NVIDIA nForce® 790i Ultra SLI
Power supply	ThermalTake 1000 W
CPU	Intel Core 2 Extreme QX9650 Yorkfiled 3.0 GHz 12 MB L2 Cache LGA 775 130 W Quad-Core processor
SDRAM	DDR3 1333; 2 - 1 GB OCZ memory cards
PC operating system	Windows XP 32-bit
GPU computing processing board	Tesla C1060
BIOS	62.00.1E.00.00
Display driver	177.83
GPU	Tesla T10
Clock speed	1.296 GHz (core) 800 MHz (mclk)

Table 8. Sample Thermal Results and Specification

Test Application	T <sub>junction</sub> (°C)*	T <sub>A</sub> (°C)**	Cooling solution
Test 1: 3DMark06/GT2 Firefly	87	45.4	Fan sink solution, NV P/N 580-10607-2000-000
GPU junction maximum temperature specification under any operating conditions	102	At any ambient temperature	

\* Junction temperature is reported by NVIDIA thermal sensor

\*\* Ambient air temperature - average of 3 sensors positioned at the inlet to the GPU fan

# COOLING SOLUTION

NVIDIA will utilize a Cooler Master TM72 active fan sink (Figure 7) to cool the GPU, memories and power supply components. For fan and environmental specifications refer to Table 9 and Table 10.

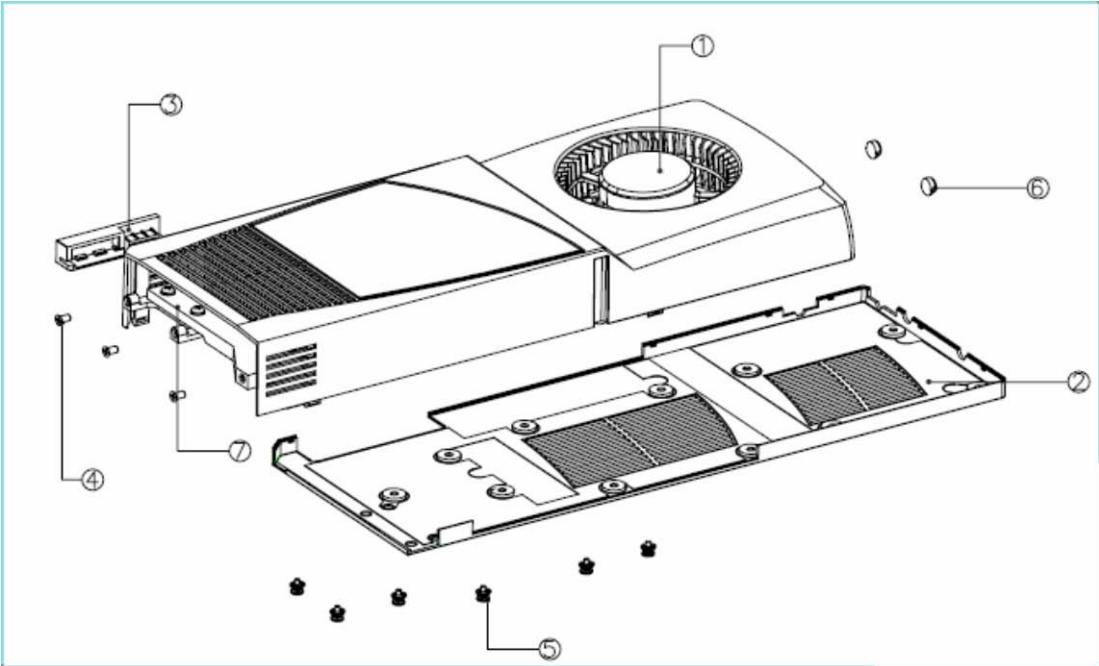

Figure 7. TM72 Active Fan Sink

Table 9. Fan Specifications and Conditions

Specifications	Conditions
Rated voltage	12 V DC
Operating voltage	5 V ~ 13.2 V DC
Start up voltage	5.0 V (at 100% duty cycle at 25 °C power on/off)
Rated current	0.48 Amp
Rated power	5.76 W
Speed	2600 ± 10% RPM (at 25 °C to record speed after fan running normal. This time is about 3 - 5 minutes)
Speed (with customer's pillow)	2600 RPM ± 10%
Airflow (at zero static pressure with customer's pillow)	14.08 CFM (minimum 12.67 CFM)
Air pressure (at zero static pressure with customer's pillow)	11.21 mm water (minimum 9.08 mm water)
Acoustic noise	39.4 dB(A); maximum 43.3 dB(A)
Noise (with customer's pillow)	46.0 dB(A); maximum 50.6 dB(A)
Life expectance	70,000 hours continuous operation at 40 °C with 15 - 65% relative humidity

Table 10. Environmental Specifications and Conditions

Specifications	Conditions
Operating temperature	0 °C to 45 °C
Storage temperature	-40 °C to 70 °C
Operating humidity	5% to 90% RH
Storage humidity	5% to 95% RH

# SUPPORT INFORMATION

## CERTIFICATES AND AGENCIES

### Agencies

- ▶ Australian Communications Authority and Radio Spectrum Management Group of New Zealand (C-Tick)
- ▶ Bureau of Standards, Metrology, and Inspection (BSMI)
- ▶ Conformité Européenne (CE)
- ▶ Federal Communications Commission (FCC)
- ▶ Industry Canada - Interference-Causing Equipment Standard (ICES)
- ▶ Korean Communications Commission (KCC)
- ▶ Underwriters Laboratories (cUL, UL)
- ▶ Voluntary Control Council for Interference (VCCI)

## LANGUAGES

Table 11. Languages Supported

	Windows XP	Linux
English (US)	X	X
English (UK)	X	
Arabic	X	
Chinese, Simplified	X	
Chinese, Traditional	X	
Danish	X	
Dutch	X	
Finnish	X	
French	X	
French (Canada)	X	
German	X	
Italian	X	
Japanese	X	
Korean	X	
Norwegian	x	
Portuguese (Brazil)	X	
Russian	X	
Spanish	X	
Spanish (Latin America)	X	
Swedish	X	
Thai	X	

**NOTE:** NVIDIA's CUDA™ software is only supported in English (U.S.)

## Notice

ALL NVIDIA DESIGN SPECIFICATIONS, REFERENCE BOARDS, FILES, DRAWINGS, DIAGNOSTICS, LISTS, AND OTHER DOCUMENTS (TOGETHER AND SEPARATELY, "MATERIALS") ARE BEING PROVIDED "AS IS." NVIDIA MAKES NO WARRANTIES, EXPRESSED, IMPLIED, STATUTORY, OR OTHERWISE WITH RESPECT TO THE MATERIALS, AND EXPRESSLY DISCLAIMS ALL IMPLIED WARRANTIES OF NONINFRINGEMENT, MERCHANTABILITY, AND FITNESS FOR A PARTICULAR PURPOSE.

Information furnished is believed to be accurate and reliable. However, NVIDIA Corporation assumes no responsibility for the consequences of use of such information or for any infringement of patents or other rights of third parties that may result from its use. No license is granted by implication of otherwise under any patent rights of NVIDIA Corporation. Specifications mentioned in this publication are subject to change without notice. This publication supersedes and replaces all other information previously supplied. NVIDIA Corporation products are not authorized as critical components in life support devices or systems without express written approval of NVIDIA Corporation.

## HDMI

HDMI, the HDMI logo, and High-Definition Multimedia Interface are trademarks or registered trademarks of HDMI Licensing LLC.

## Macrovision Compliance Statement

NVIDIA Products that are Macrovision enabled can only be sold or distributed to buyers with a valid and existing authorization from Macrovision to purchase and incorporate the device into buyer's products.

Macrovision copy protection technology is protected by U.S. patent numbers 5,583,936; 6,516,132; 6,836,549; and 7,050,698 and other intellectual property rights. The use of Macrovision's copy protection technology in the device must be authorized by Macrovision and is intended for home and other limited pay-per-view uses only, unless otherwise authorized in writing by Macrovision. Reverse engineering or disassembly is prohibited.

## OpenCL

OpenCL is a trademark of Apple Inc. used under license to the Khronos Group Inc.

## Trademarks

NVIDIA, the NVIDIA logo, CUDA, HybridPower, nForce, SLI and Tesla are trademarks or registered trademarks of NVIDIA Corporation in the U.S. and other countries. Other company and product names may be trademarks of the respective companies with which they are associated.

## Copyright

© 2008, 2009, 2010 NVIDIA Corporation. All rights reserved.